



MT174

Three-Phase Static Electricity
Multi Tariff Meter
with Maximum Demand Indicator
and Load-profile

Technical Description

Version 1.2, 18.08.2011



Index:

MT174 - Electronic three-phase time-of-use electricity meters.....	3
MT174 meter properties:.....	4
1. Meter appearance.....	6
1.1. Meter case.....	6
1.2. Terminal block.....	6
1.2.1. Terminal block for direct connected meters	6
1.2.2. Terminal block of CT operated meters.....	7
1.2.3. Auxiliary terminals.....	7
1.3. Over-all dimensions.....	8
1.4. Meter sealing places	8
2. Meter configuration.....	9
2.1. Metering elements.....	9
2.2. Power supply stage.....	9
2.3. Microcontroller.....	9
2.3.1. Load-profile recorder.....	9
2.3.2. Log-book	10
2.3.3. Billing results keeping	10
2.4. Real-time clock.....	11
2.4.1. RTC back-up power supply.....	11
2.4.2. RTC accuracy testing.....	11
2.4.3. Time-of-use registration	11
2.4.3.1. Sleeping (passive) tariff program	11
2.4.3.2. Holidays.....	12
2.4.4. Maximum demand measurement	12
2.4.5. Meter billing reset.....	12
2.5. LCD	12
2.5.1. LCD testing	13
2.5.2. Data display	13
2.5.2.1. Meter test mode	13
2.5.3. Signal and alarm flags	13
2.5.3.1. Deleting alarm flags	14
2.5.4. No-power reading option	14
2.6. LEDs	14
2.7. Push-buttons.....	14
2.7.1. Display testing	15
2.7.2. Manual data display.....	15
2.7.3. Manual meter billing reset	15
2.7.4. Meter setting mode.....	16
2.7.4.1. Setting RTC time by pushbuttons	16
2.7.4.2. Setting RTC date by pushbuttons	16
2.7.4.3. Setting Baud rates by pushbuttons	17
2.7.4.4. Meter parameters setting mode ..	17
2.7.4.5. Deleting alarm flags by pushbuttons.....	17
2.7.5. Meter testing mode.....	17
2.7.6. Driving menus with pushbuttons.....	18
2.7.7. Flowchart of time setting with pushbuttons	19
2.8. Communication channels	20
2.8.1. Optical port	20
2.8.2. RS485 interface.....	20
2.8.3. Data downloaded via optical port	20
2.8.4. Fatal error register	20
2.8.5. Communication protocol.....	21
2.9. Inputs and outputs	21
2.9.1. Tariff input.....	21

2.9.2.	<i>Pulse output</i>	21	3.11.	<i>SEP2 MeterView software</i>	24
2.9.3.	<i>Tariff output</i>	22	4.	<i>Meter installation</i>	24
3.	<i>Antifraud protection</i>	22	5.	<i>Tools for meter managing</i>	25
3.1.	<i>Meter seals</i>	22	6.	<i>Meter maintenance</i>	25
3.2.	<i>Always positive registration</i>	22	7.	<i>Meter connection diagram</i>	25
3.3.	<i>Passwords</i>	22	8.	<i>Technical data</i>	26
3.4.	<i>Parameters change protected with a sealed pushbutton</i>	23	9.	<i>Meter type designation</i>	28
3.5.	<i>Detectors of opening meter cover and terminal cover</i>	23	10.	<i>Appendix I: MT174 meter in photovoltaic (PV) installations</i>	29
3.6.	<i>Detector of external magnetic field</i>	23	11.	<i>Appendix II: EDIS codes, data stored in registers, sequences, historical values</i>	30
3.7.	<i>Fraud event counters</i>	23			
3.8.	<i>Registers of elapsed time</i>	23			
3.9.	<i>Registers of fraud energy</i>	24			
3.10.	<i>Log-books</i>	24			

MT174 - Electronic three-phase time-of-use electricity meters

The MT174 electronic three-phase meters are designed for measurement and registration of active, reactive and apparent energy and demand in three-phase four-wire networks. They can be connected directly to the network. The metering and technical properties of the meters comply with the EN 50470-1 and -3 European standards for active energy meters, classes A and B, as well as with the IEC 62053-21 and IEC 62052-11 international standards for electronic meters of active energy for classes 1 and 2, and optionally with the IEC 62053-23 international standard for electronic meters of reactive energy for classes 2 and 3.

A built-in time-switch complies with the IEC 62054-21 and IEC 62052-21 standards. It enables energy registration in up to four tariffs.

The meter software complies with WELMEC 7.2 Issue 1 Software Guide (Measuring Instruments Directive 2004/22/EC).

The MT174 meters are designed for mechanical environment M1, electromagnetic environment E2 and climatic environment -40°C ... +60°C, relative humidity 95% non-condensing, closed location. The meters can be installed in any position.

The meters are designed and manufactured in compliance with the ISO 9001 (2000) standard.

MT174 meter properties:

- **Meter accuracy**
 - Class A or B in compliance with EN 50470-3 (or 2 or 1 in compliance with IEC 62053-21) for active energy
 - Class 3 or 2 for reactive energy (option)
 - Class 3 or 2 for apparent energy (option)
- **Meter software in compliance with WELMEC 7.2 Issue 1**
- **Measured quantities**
 - Energy (active, reactive and apparent)
 - Demand (active, reactive and apparent)
 - Reactive energy and demand by quadrants
 - Instantaneous power
 - Phase voltages (UL1, UL2, UL3)
 - Phase currents (IL1, IL2, IL3)
 - Phase power factors
 - Frequency
- **Modes of energy measurement and registration**
 - For one-way energy flow direction (import), with an electronic reverse running stop
 - For two energy flow directions (import, export)
 - For two-way energy flow direction, with always positive registration, i.e. energy flowing in the export direction is registered as it flows in import direction too (only for active energy)
- **Connection:**
 - Direct
 - Via CT
- **Networks:**
 - 3-phase 4-wire
 - 3-phase 3-wire
 - 1-phase 2-wire
- **Meter quality:**
 - Due to high accuracy and long term stability of the metering elements no meter recalibration is required over its lifetime
 - Long meter lifetime and high meter reliability
 - High immunity to EMC
 - Wide voltage range of measurement with declared meter accuracy: 0.3Ur to 1.3Ur
- **RTC:**
 - Accuracy better than ± 3 min/year at 23°C
 - RTC operation reserve 5 years
 - Back-up power supply Li-battery
 - Indication of low Li-battery (option)
- **Time-of-use registration (up to 4 tariffs):**
 - Tariffs change-over by internal real-time clock
- Optional tariff inputs for external tariff change-over
- **LCD-display:**
 - Large LCD in compliance with the VDEW requirements
 - EDIS code for data identification
 - LCD back-light on request
- **Data display modes:**
 - Automatic cyclic data display with default display time of 8 sec.
 - Manual data display mode (by pressing the Scroll push-button)
 - Optional data display when the meter is in no-power state
- **Indicators:**
 - **LCD:**
 - Valid tariff at the moment
 - Meter status and alarms
 - Energy flow direction
 - Phase voltage presence and phase voltage sequence
 - reversed energy flow through a particular metering element
 - **LEDs:**
 - Imp/kWh
 - Imp/kvarh (at active and reactive energy meters)
 - Imp/kVAh (at kWh-, kvarh-, kVAh-meters)
- **Powerful load-profile recorder:**
 - Up to 8-channels
 - More than 790 days of registration at 1 channel, 1-hour registration period
- **Communication channels:**
 - Infrared optical port in compliance with IEC 62056-21 for local programming and data down-loading
 - RS485 serial interface (option)
 - Protocol IEC 62056 - 21, mode C
- **Pulse outputs:**
 - Class A by IEC 62053-31 (option)
 - Optomos relay with make contact (option)
- **Plastic meter case:**
 - Made of high quality self-extinguishing UV stabilized material that can be recycled
 - Double insulation
 - IP54 protection against dust and water penetration (by IEC 60529)
- **Mechanical environment: M1**
- **Electromagnetic environment: E2**

-
- **At direct connected meters:**
 - **Current terminals**
 - Assure good connection with all types of conductors
 - Do not damage conductors
 - **Potential links**
 - Sliding self-braking potential links enable quick disconnection of current and voltage circuitries
 - Can be located in a terminal block compartment or under a meter cover
 - **Antifraud functions:**
 - **Detectors** (optional)
 - meter cover opening
 - terminal cover opening
 - reversed energy flow direction
 - external permanent magnetic field
 - **Indicators** (optional)
 - meter cover opening
 - terminal cover opening
 - reversed energy flow direction through each of metering elements
 - external permanent magnetic field
 - **Fraud energy registers** (optional)
 - energy consumed since the meter cover has been opened
 - energy consumed since the terminal cover has been opened
 - energy consumed since reversed energy flow has been detected
 - energy consumed since external permanent magnetic field has been detected
 - **Counters of events** (optional)
 - meter cover opening
 - terminal cover opening
 - reversed energy flow direction
 - external permanent magnetic field
 - **Counters of elapsed time** (optional)
 - since meter cover has been opened
 - since terminal cover has been opened
 - since reversed energy flow has been detected
 - since external permanent magnetic field has been detected
 - of total energy registration
 - of energy registration in a particular tariff
 - **Time-stamps** (optional)
 - of the last meter cover opening
 - of the last terminal cover opening
 - of the last reversed energy flow detection
 - of the last external permanent magnetic field tampering
 - **Change of set parameters protected with a sealed pushbutton** (optional)
-

1. Meter appearance

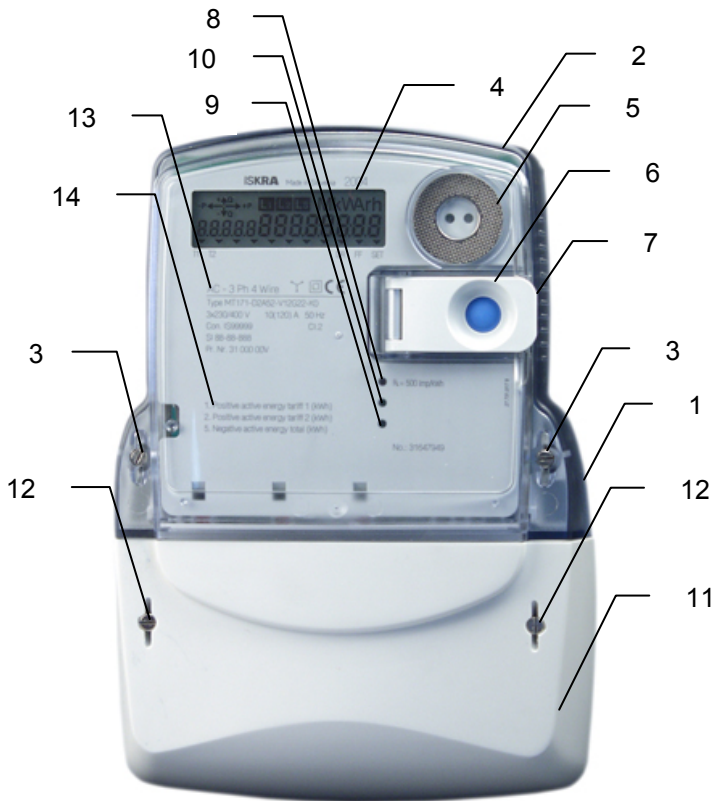

Fig. 1: Meter parts

- | | |
|-----------------------------|---------------------------------|
| 1. Meter base | 8. LED imp/kWh |
| 2. Meter cover | 9. LED imp/kvarh (option) |
| 3. Meter cover fixing screw | 10. LED imp/kVAh (option) |
| 4. LCD | 11. Terminal block cover |
| 5. Optical port | 12. Terminal cover fixing screw |
| 6. Scroll push-button | 13. Meter data |
| 7. Reset push-button cover | 14. Legend |

Screws for fixing the meter cover (item 3) are sealed with metrological seals.

Screws for fixing the terminal block cover (item 12) are sealed with seals of electric utility.

1.1. Meter case

A compact meter case consists of a meter base (item 1) with a terminal block and three fixing elements for mounting the meter, a meter cover (item 2) and a terminal block cover (item 11). The meter case is made of self-extinguishing UV stabilized polycarbonate which can be recycled. The meter case ensures double insulation and IP54 (IEC 60529) protection level against dust and water penetration.

On the back side of the meter base under the top edge there is the top meter fixing element. On request an extended plastic or metal top fixing element can be attached to the back side of the meter base.

The meter cover is made of transparent polycarbonate. It is fixed to the meter base with two sealing screws, which prevents access to the meter interior without breaking the seals.

A nickel-plated iron ring in the right top corner is used for attaching an optical probe to the optical port (item 5). A push-button for data scrolling is positioned on the meter right side (item 6). The reset push-button cover (item 7) is joined with a hinge to the meter cover and can be sealed independently.

1.2. Terminal block

The terminal block is made of self-extinguishing polycarbonate. It can be used either for direct or CT meter connection.

The terminal block cover (item 11) can be long or short. A meter connection diagram is stuck on its inner side. The terminal block cover is fixed with two sealing screws (item 12).

1.2.1. Terminal block for direct connected meters

The terminal block for direct connected meters contains current terminals, auxiliary terminals and potential links for power supply of the voltage metering circuitry.

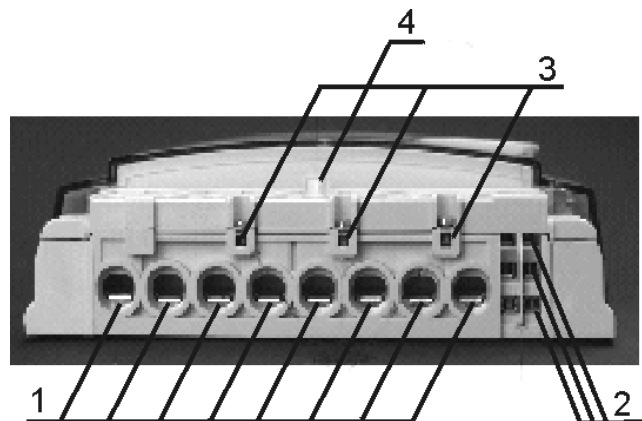

Fig. 2: Terminal block of direct connected meters

- | | |
|------------------------|---|
| 1. Current terminals | 3. Auxiliary voltage terminals for an add-on unit |
| 2. Auxiliary terminals | 4. Terminal cover opening detector |

The current terminals (item 1) are cage type and are made of nickel plated steel. They are universal terminals for all types of conductors made either of copper or aluminium. The current terminals are made in two sizes:

- For conductors with maximum cross section up to 25 mm² ($I_{max} = 85$ A),
- For conductors with maximum cross section up to 35 mm² ($I_{max} = 120$ A).

The 85 A terminal blocks has only one screw per current terminal, while 120 A terminal blocks has two screws per current terminal. Due to indirect pressure to the conductors the terminal screws do not damage it. The current terminals make a reliable and durable contact regardless if the conductor is made of copper or aluminium.

Voltage metering elements are power supplied via potential links. Sliding potential links are self-braking and enable easy disconnection of current and voltage metering circuitry. In the metering mode they should be in their lowest position (closed contact), and in the meter testing mode they should be in their highest position (opened contact). On request, the potential links can be located under the meter cover.

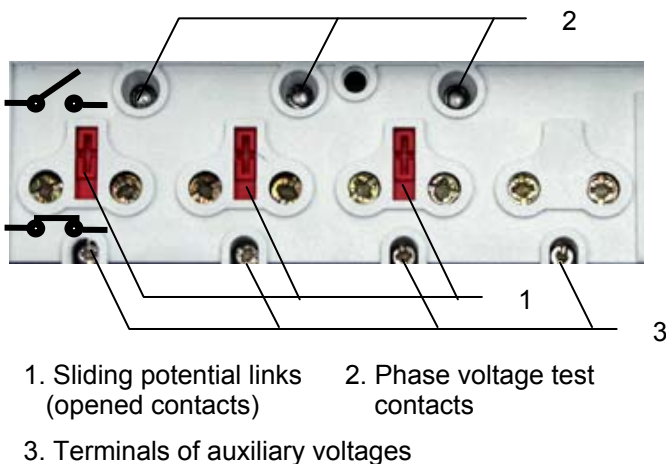

- 1. Sliding potential links (opened contacts)
- 2. Phase voltage test contacts
- 3. Terminals of auxiliary voltages

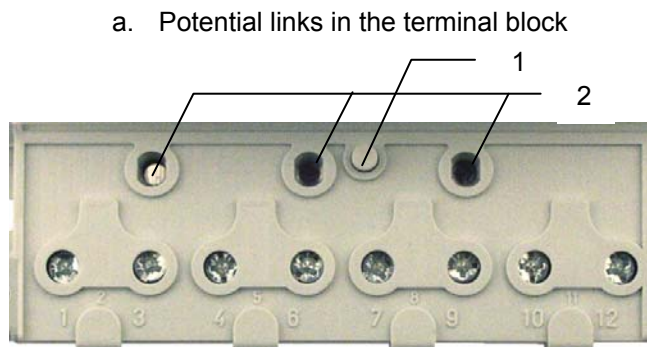

- 1. Detector of terminal cover opening
- 2. Phase voltage test contacts

b. Potential links under meter cover

Fig. 3: Terminal blocks of direct connected meters for $I_{max} = 85 A$

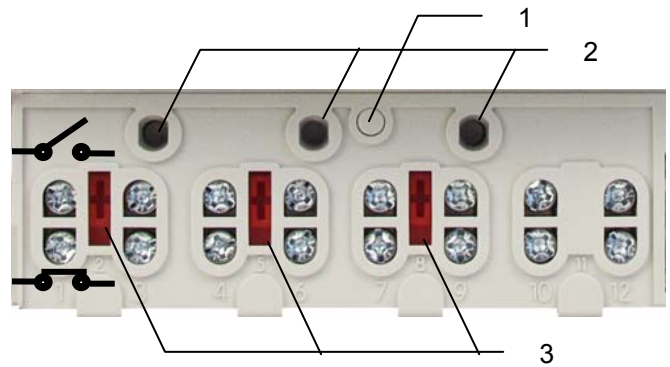

- 1. Detector of terminal cover opening
- 2. Phase voltage test contacts
- 3. Sliding potential links (opened contacts)

Fig. 4: Potential links in the terminal block of direct connected meters for $I_{max} = 120 A$

1.2.2. Terminal block of CT operated meters

The CT operated meters have separate voltage terminals (Fig. 5, item 2) in the terminal block. They are used for supplying the voltage metering circuitry. The voltage terminals are equal to the current terminals (Fig. 5, item 1). The current and voltage terminals are made of solid brass with a 5 mm bore diameter; the conductors are fixed in the terminals with two screws.

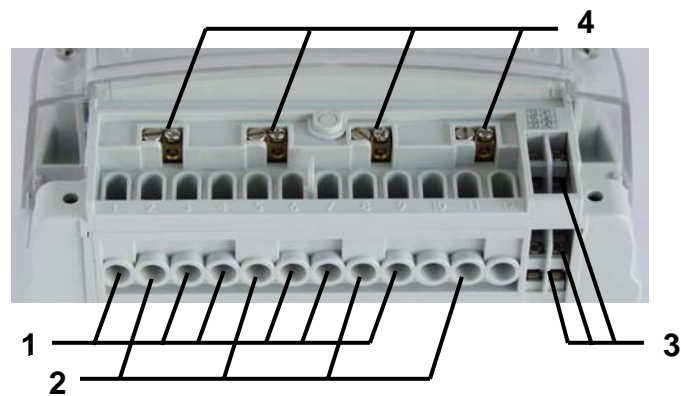

- 1. Current terminals
- 2. Voltage terminals
- 3. Auxiliary terminals
- 4. Auxiliary voltage terminals for add-on unit

Fig. 5: Terminal block of a CT operated meter

1.2.3. Auxiliary terminals

Up to six auxiliary terminals can be built in a terminal block. They are used for tariff inputs, impulse outputs or tariff outputs or RS485 interface. Due to a limited number of auxiliary terminals, all stated inputs and outputs as well as the interface can not be built in the meter at the same time. The bore diameter of the auxiliary terminals is 3.5 mm. Wires are fixed with a screw. Three auxiliary

voltage terminals for power supply of an external device can be also built-in.

The auxiliary terminals are nickel-plated at a tropical meter version.

The auxiliary terminals enable combinations of the following meter functionalities:

Version	Left side auxiliary terminals	Right side auxiliary terminals
1	Two tariff inputs	Two pulse outputs
2	Two tariff inputs	RS485 interface
3	Two pulse or tariff outputs	RS485 interface

1.3. Over-all dimensions

Meter fixing dimensions comply with the DIN 43857 standard.

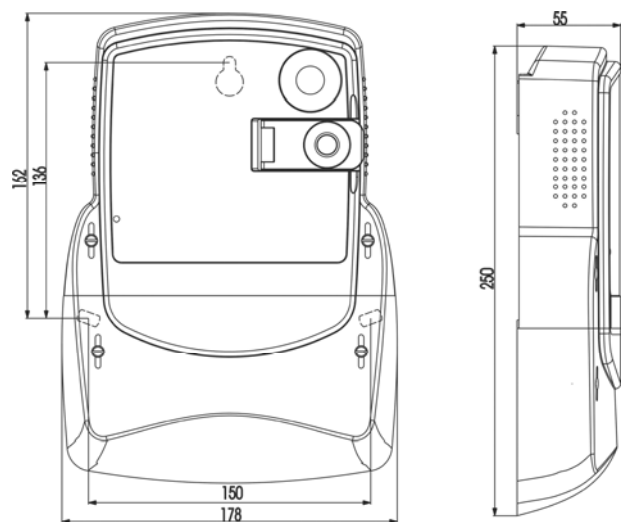

Fig. 6 - Meter with a long terminal cover

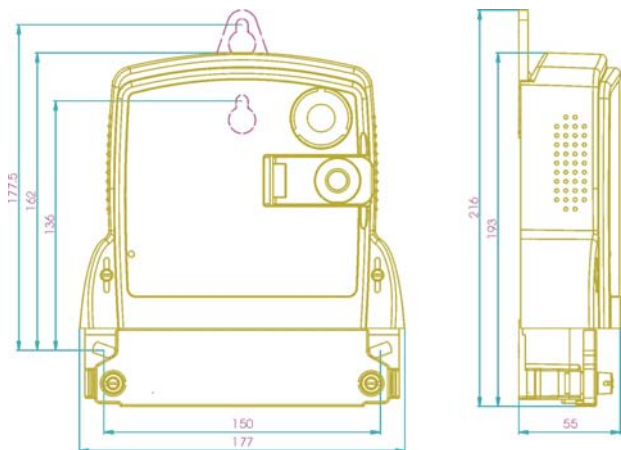

Fig. 7 - Meter with a short terminal cover and an additional top meter fixing element

Note:

On request, an additional top meter fixing element shown in Fig. 7 can be attached to the MT174 meters with a long terminal cover (shown in Fig. 6).

1.4. Meter sealing places

The meters are sealed at the following places:

1. The screws of the meter cover - metrological seals
2. The screws of the terminal cover - electric utility seals
3. The hinged cover of the Reset pushbutton - electric utility seals

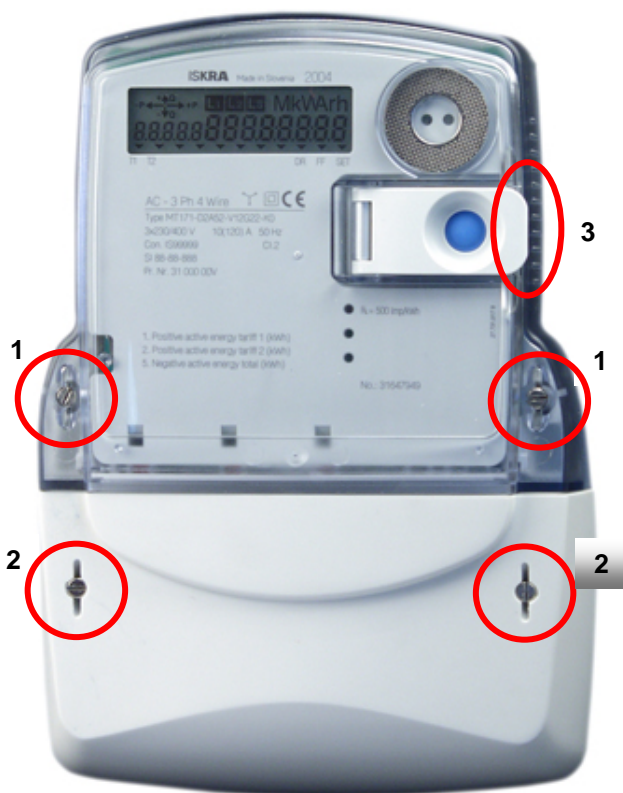

Fig. 8 - Places of sealing the MT174 meters

2. Meter configuration

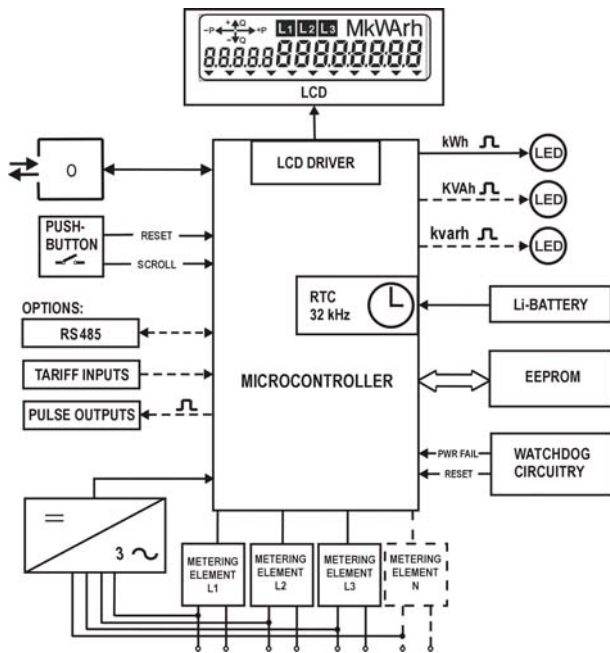

Fig. 9: Meter block-diagram

The meter consists of:

1. Three (on request four) metering elements
2. Meter power supply unit
3. Microcontroller with EEPROM
4. RTC with a Li-battery
5. LCD
6. Pulse emitting LED(s)
7. Scroll push-button
8. Reset push-button
9. IR optical port
10. RS 485 (option)
11. Tariff input(s) (option)
12. Pulse output(s) or tariff output(s) (option)

2.1. Metering elements

The MT174 meters are equipped with three metering elements.

The metering elements enable accurate measurement of active, reactive and apparent energy in a wide metering and a temperature range. The voltage range is from $0.3U_r$ to $1.3U_r$ - within it the MT174 meters measure energy with declared accuracy.

The metering elements consist of a current and a voltage sensor. The current sensor is a Rogowski coil (a current transformer with an air core), while the voltage sensor is a resistive voltage divider. Signals of currents and voltages are fed to the A/D converters. Then they are digitally multiplied so that instantaneous power is calculated. The instantaneous power is integrated in the microcontroller, where it is further processed.

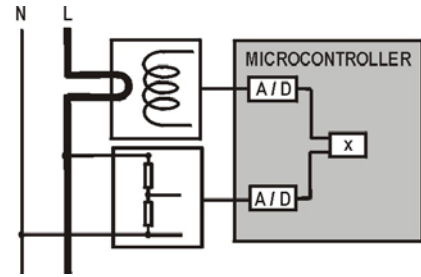

Fig. 10: Metering element

The metering element ensures excellent metering properties:

1. Negligible effect of influence quantities and electromagnetic disturbances
2. High long-term stability so that meter recalibration is not required over its lifetime
3. Long meter lifetime and high reliability in use

2.2. Power supply stage

The power supply stage is a capacitor type and is supplied with all three phase voltages. It enables a meter to operate accurately also if just one phase and neutral or two phases are connected to the meter, and the voltage range is from 80% to 120% of the rated voltage.

2.3. Microcontroller

The microcontroller acquires signals from the metering elements, processes them and calculates values of measured energy. The metering results are stored in energy registers for particular tariffs and total. The microcontroller also generates pulses for the LED(s) and pulse output(s), enables two-way communication via the optical port and a serial interface (if built-in), records load profile and events as well as drives the LCD.

All measured data are stored in a non-volatile memory and are kept for more than 10 years period without an external power supply.

Operation of the microcontroller is controlled with a watchdog.

2.3.1. Load-profile recorder

A load-profile recorder is provided with maximum eight channels. The recording period can be set to 5, 15, 30 or 60 minutes.

Note: If maximum demand is measured too, load-profile registration period and demand period should be of the same value.

Energy or demand can be registered in load-profiles. Data in the load-profile recorder are provided with a time stamp (date and time of the end of a registration period), a meter status in the last registration period and a check sum. A capacity of the load-profile recorder depends on the registration period and a number of registered quantities (channels) and is given in the following table.

Number of channels	Load-profile capacity (days)		
	Reg. period 60 min	Reg. period 30 min	Reg. period 15 min
1	793	396	198
2	476	238	149
3	340	170	85
4	261	130	65
5	214	107	53
6	182	91	45.5
7	158	79	39.5
8	140	70	35

Warning: If the registration period is changed, the data stored in the load profile will be lost. Before changing load-profile registration period the load-profile data must be downloaded first in order not to be lost.

The following data can be stored in the load-profile:

- Positive active energy +A or demand +P
- Negative active energy -A or demand -P
- Absolute active energy |A| or demand |P|
- Positive reactive energy +R or demand +Q
- Negative reactive energy -R or demand -Q
- Reactive energy in first quadrant R1 or demand Q1
- Reactive energy in second quadrant R2 or demand Q2
- Reactive energy in third quadrant R3 or demand Q3
- Reactive energy in fourth quadrant R4 or demand Q4
- Apparent energy S

Note: Load-profile data can't be displayed on the LCD.

2.3.2. Log-book

The MT174 meters have two log-books. The log-book P.98 can register 209 events and meter statuses; the log-book P.98.1 can register 74 events - mostly fraud attempts. The log-books are organized as a FIFO memory. In this way the last 209 respectively 74 events are always available. Every registered event or meter status is accompanied with a time stamp consisting of date and time when it has occurred.

The following events and meter statuses can be registered in the P.98 log-book:

- Fatal meter error
- Meter billing reset
- Watch-dog reset
- Changed a value of set parameters
- Changed load-profile registration period
- Internal clock setting
- Day-light save period time change
- Network voltage failure

- Restoration of network voltage
- Deleted registers of the load-profile recorder
- Deleted registers of the log-books 0 and 1
- Deleted energy registers
- Voltage failure in individual phase (L1, L2, L3)
- Restoration of voltage in individual phases (L1, L2, L3)
- Voltage lower than set voltage low limit
- Voltage higher than set voltage high limit
- Opening / closing the meter cover
- Opening / closing the terminal block cover
- Manipulation with a permanent magnet start / stop
- Energy flowing in reversed direction (only at meters for one energy flow direction and at absolute meters)
- Energy loss detected
- Fraud start / stop
- Phase voltages L1, L2, L3 below the low voltage limit
- Phase voltages L1, L2, L3 under the high voltage limit
- Phase voltages L1, L2, L3 within voltage limits
- Wrong password
- Li-battery low

The following events and meter statuses can be registered in the P.98.1 log-book:

- Opening / closing the meter cover
- Opening / closing the terminal block cover
- Manipulation with a permanent magnet start / stop
- Energy flowing in reversed direction (only at meters for one energy flow direction and at absolute meters)
- Deleted log-book P.98
- Deleted load-profile recorder
- Deleted energy registers
- Change of the meter parameters
- Fraud start / stop
- Watch-dog reset
- Wrong password / log-in
- Energy loss detected

2.3.3. Billing results keeping

The MT174 meter keeps billing results (energy and maximum demand values registered by tariffs and total) for up to the last 15 billing periods (months). A number of billing periods (months) for which billing results are kept is set in the factory and can't be changed subsequently. The billing results are stored in a FIFO memory, so that they are always available for the last n (n = 1, 2, ..., 15) billing periods (months), regardless if the meter billing reset was performed by means of the RTC, the Reset push-button or via the optical port or remotely via a serial interface. The metering results of the past billing periods (months) can be displayed for max. 9 previous months, while they can be readout

for 15 previous months by means of the optical port or the serial interface (if it is built-in).

The RTC can be set to perform a billing reset:

- Once a year on a specified date and time
- Every month on specified day in a month and time
- Every month on a specified day in a week after specified day in a month and specified time
- Every week on a specified day in a week and time
- Every day

Indexation of the registers keeping previous month billing data can be either linear (running from 01 to 15) or circular (running in circles from 00 to 99 and then again 00 and so on).

2.4. Real-time clock

A real-time clock is controlled with a 32.768 kHz quartz crystal which is digitally trimmed. Its accuracy is better than requested by the IEC 62054-21 standard for time-switches. The RTC involves an internal calendar that assures information on year, month, day, day in a week, hour, minute, second and leap year.

The RTC enables:

- Time-of-use registration (in max. 4 tariffs)
- Generating a demand period and load-profile registration period
- Generating of time stamp (date and time) for demand and events in the log-books
- Automatic meter billing reset at the end of the billing period (month)
- Automatic change-over to day-light saving period and back to the standard time (winter - summer time)

2.4.1. RTC back-up power supply

A Li-battery is used as the RTC back-up power supply. It assures 5 years of the RTC operation reserve and has 20-year shelf-life. The Li-battery is positioned on the meter printed circuit board under the meter cover.

The Li-battery can enable data display on the LCD when the meter is in a no-power state (see item 2.5.4 No-power reading option).

2.4.2. RTC accuracy testing

The RTC accuracy is tested via imp/kWh LED (Fig. 1, item 8) when the meter is in the RTC test mode. The meter is set in the RTC test mode operation via an optical interface by means of Iskraemeco MeterView software by sending the **Clock control** command to the meter. When the meter is in the RTC test mode, 4.096 Hz test frequency of RTC is fed to the imp/kWh LED (Fig.1, item 8). The meter exits the test mode operation by:

- Sending a command for exiting the RTC test mode operation by means of MeterView software
- Disconnecting meter supply voltage

2.4.3. Time-of-use registration

The meter is designed as a multi-tariff with maximum four tariffs. A tariff change-over time is defined with hour and minute. Minimal time period between change-over is five minutes. The real-time clock enables complex daily and weekly tariff structures, as well as a couple of seasons in a year:

- Up to 10 seasons in a year (i.e. 10 weekly tariff programs)
- Up to 10 daily definitions of the tariff change-over program
- Up to 10 tariff change-over inside individual daily tariff programs
- Up to 46 holidays (including those based on a lunar calendar) in which a special tariff program is defined

The tariff programs control both energy end maximum demand registration.

Tariffs can be changed-over also via tariff inputs - maximum two tariff inputs are available for changing-over up to four tariffs. When tariff inputs are used for tariff change-over the active tariff valid both for energy and demand.

2.4.3.1. Sleeping (passive) tariff program

On request two tariff programs are available. The second tariff program can be used as:

1. Separate tariff program for maximum demand - if this option is selected, the first tariff program controls energy registration and the second tariff program controls maximum demand registration
2. Sleeping (passive) tariff program for both (energy and maximum demand registration) - with this option also the start date (day, month and year) for activation of passive tariff program must be defined:
 - a. If current date is before start date, the first tariff program is active
 - b. On start date at 00:00:00 the meter switches from first to second tariff program (there is no overwriting of tariff programs, both tariff programs stay intact and in the same place as before switching)
 - c. If current date is equal to or later than start date, the second tariff program is active
 - d. RTC setting:
 - If the second tariff program is active and RTC is set to date before start date, the meter switches from second to first tariff program

- If the first tariff program is active and RTC is set to date after start date, the meter switches from first to second tariff program

2.4.3.2. Holidays

The MT174 meters support the following holidays:

- Single (on defined year, a month and a day in a month)
- Every year (on defined month and a day in a month)
- Every year with shift to Monday (on defined month and a day in a month and if that date is on Sunday, the holiday is shifted to Monday)
- Holidays based on Lunar calendar

For holidays based on Lunar calendar the reference holiday is Eastern according to Gregorian calendar. All other lunar holidays are defined with a number of days before or after the Eastern for that holiday - shifted days. When defining the other lunar holidays by shifted days, care should be taken that the entered number of shifted days will not cause that the defined lunar holiday will be in the next or the previous year.

2.4.4. Maximum demand measurement

The internal clock generates a demand period for demand calculation. Demand is calculated as a mean value in the integration period. In the MT174 meters the following demand periods can be set: 5, 15, 30 or 60 minutes. At the end of a demand period the calculated demand is transferred from the current demand period register into the register of the demand period that was just terminated. It is compared with the value stored in the maximum demand register in the billing period. If the new calculated demand is greater than the value in the maximum demand register, a new demand value is stored, otherwise the old value is kept. In this way, a maximum demand is also registered at the meter billing reset.

Note: If the meter registers load-profile, the demand period and the load-profile registration period should be of the same length.

2.4.5. Meter billing reset

A meter billing reset is usually done by RTC once a month. However, any other period of a meter billing reset can also be set (see Item 2.3.3 “Billing results keeping”). Day and time of the meter billing reset can be set for any day in a month and any time during a day. At the meter billing reset the billing data for a current month are copied from the registers for a current month (a billing period) to the registers of a previous month (a billing period) and registers for maximum demand in a current billing period (month) are cleared. At the same time the

maximum demand value is added to a sum of maximum demands in the cumulative demand register and a counter of billing resets is incremented.

The meter billing reset can be performed not only by means of RTC but also by pressing the Reset push-button (see Item 2.7.3 “Manual meter billing reset”), via the IR optical port or remotely via a serial interface, if it is built-in.

2.5. LCD

The 7-segment LCD, with additional characters and symbols, complies with the VDEW specifications. Large characters and a wide angle view enable easy data reading. The LCD back-light illumination is available on request. The LCD is illuminated by short ($T_p < 2$ s) pressing the blue pushbutton. On request the back-light is turned-on all the time.

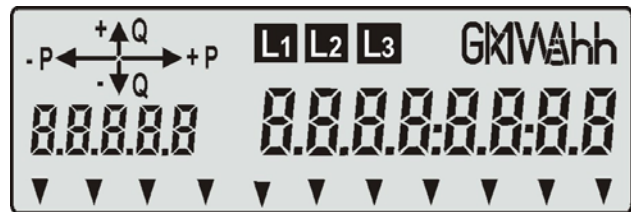

Fig. 11: LCD

Data are displayed in the right-side by means of eight alphanumeric characters. The size of data characters is 8 mm high and 4 mm width. The OBIS code (by IEC 62056-61), without the first two characters from the left side, is employed for data identification. It is displayed in the left side corner by means of five 6 mm high alphanumeric characters.

An indicator of energy flow direction is displayed in the left top corner.

Note: If there is no load or the load current is lower than the meter starting current, the indicator of energy flow direction is not displayed.

A physical unit of displayed physical quantity is shown in the right top corner. The indicator of L1, L2, L3 phase voltages presence is displayed in the middle of the top row. If certain phase voltage is not present, the indicator of that phase is not displayed.

When the indicators L1L2L3 blink, this indicates wrong phase sequence.

When the indicator L1, L2 or L3 blinks and at the same time the arrow ← indicating export energy flow direction is displayed, it indicates reverse energy flow through the metering element in that phase.

In the LCD bottom row there are eleven signal flags that indicate current valid tariff, meter status and alarms. The meaning of signal flags (see item 2.5.3) is engraved on the meter name plate below them.

2.5.1. LCD testing

The LCD can be tested automatically so that all LCD segments are displayed (Fig. 11) for 5 seconds to check whether they are in order.

The LCD test can be performed either:

- After voltage is applied to the meter
- In Auto scroll sequence or
- In Manual scroll sequence
- With a command sent via a communication interface

2.5.2. Data display

Data defined in Auto scroll sequence and in Manual scroll sequence are displayed on the LCD.

Data from Auto scroll sequence are displayed in a circle, and each data is displayed for 8 seconds as a standard (default) display time. On request, longer or shorter data display time can be set via the meter optical port by means of Iskraemeco MeterView software.

Note: Maximum 34 registers can be included in the AUTO scroll mode

At Manual scroll sequence the blue push-button should be pressed for displaying the next piece of data. Data in Manual scroll sequence remains displayed until the push-button is pressed again or until time for automatic return into the Auto scroll sequence is elapsed.

On request, billing data for the maximum 9 elapsed billing periods (months) can be displayed in the LCD too.

Note: Maximum 50 registers can be included in the MANUAL scroll mode

Data that can be displayed at different meter configurations required by the customer are shown in the table in the **Appendix: Data registers and sequences**.

Energy data and demand can be displayed in data formats given in the table below.

Data format	No. of integers	No. of decimals
Energy		
6.0	6	0
7.1	6	1
7.0	7	0
8.2	6	2
8.1	7	1
8.0	8	0
Maximum demand		
4.2	2	2
4.3	1	3
Cumulative maximum demand		
6.2	4	2
6.3	3	3

2.5.2.1. Meter test mode

The MT174 meters can be set into the meter test mode via their optical port by means of Iskraemeco MeterView software (SET menu) or by means of the pushbuttons on the meter front side (see item 2.7.6 Driving menus with pushbuttons) in which energy data are displayed with higher resolution. Four decimals are displayed in the meter test mode (if not requested less decimals to be displayed). At the same time imp/kWh (and imp/kvarh LED and imp/kVA if they are built-in) starts to emit pulses with a pulse rate 40.000 imp/kWh (40.000 imp/kvarh, 40.000 imp/kVAh). In this way time needed for meter accuracy testing at low load is shortened.

2.5.3. Signal and alarm flags

The signal flags in the LCD bottom row indicate certain meter status and alarms. They are grouped into three groups:

- actual tariff (first four flags on the left side)
- alarms (four flags in the middle)
- meter status (last three flags on the right side)

The MT174 meters enable indication of many different alarms but only four of them can be displayed on the LCD. Therefore a customer at meter ordering should specify which of them are to be displayed on the LCD. If more than four alarms are to be indicated on the LCD, one signal flag can be used for two different alarms (e.g. one signal flag for both the meter cover and the terminal cover opening)

The signal flags from left to right have the following functions:

No.	FLAG	STATUS	MEANING
1	T1	Lit	Active first tariff
2	T2	Lit	Active second tariff
3	T3	Lit	Active third tariff
4	T4	Lit	Active fourth tariff
5 to 8	TC	Lit	Terminal cover has been opened ¹⁾ (option)
	MC	Lit	Meter cover has been opened ¹⁾ (option)
	FD	Lit	Field detector ²⁾ (meter has been tampered with a permanent magnet - option)
	REV	Lit	Energy flowing in reversed direction ³⁾ (option)
	BAT	Lit	Li-battery low ⁴⁾
	PD	Lit	Data display on LCD in no-power meter state ⁵⁾
9	DRO	Lit	Meter data downloading is in progress

10	FF	Lit	Meter fatal error ⁶⁾
11	SET	Lit	Meter in programming mode

- 1) The flag is active only if a corresponding cover opening detector is built into the meter.
- 2) The flag is active only if an external magnetic field detector is built into the meter (option)
- 3) The flag could be implemented only at one direction energy flow and at absolute energy meters
- 4) The flag indicates that Li-battery is low and should be replaced.
- 5) The flag is active only if no-power data displaying in the LCD was requested (option)
- 6) If the FF signal flag is displayed, the meter should be dismounted from a place of measurement and sent to an authorized repair shop or to the manufacturer for examination and repair. At the same time the F.F.0 register is displayed. For its meaning see item 2.8.4 Fatal error register.

2.5.3.1. Deleting alarm flags

The alarm flags displayed on the LCD remain displayed even in a case of power-down / power-up. They can be deleted by:

- sending a formatted command to the meter via its optical port or serial interface (if built-in)
- the meter pushbuttons - one of them is sealed (see item 2.7.4.5 Deleting alarm flags by push-buttons)

The customer should specify how the alarm flags are to be deleted at meters ordering.

2.5.4. No-power reading option

Optionally, data can be displayed on the LCD in a no-power meter state by pressing the Scroll push-button. Data from the Manual scroll sequence (with exception of historical data if they are included in this sequence) are displayed on the LCD in the no-power reading mode. For displaying each data on the LCD the Scroll pushbutton should be pressed again. If the Scroll pushbutton has not been pressed for a time longer than the time of scrolling data in the Auto display mode, the LCD automatically turns-off in order to save the Li-battery.

2.6. LEDs

The meters for active energy only are provided with a LED (imp/kWh). The meters for active and reactive energy are provided with two LEDs (imp/kWh and imp/kvarh). The meters for active, reactive and apparent energy are provided with three LEDs (imp/kWh, imp/kVAh and imp/kvarh). The LED(s) are used for testing the meter accuracy and indicating meter operation. If current through

the meter is smaller than the meter starting current, the LEDs (or a LED) are (is) permanently lit.

LED	STATUS	INDICATION
Imp/kWh Imp/kVAh Imp/kvarh	Blinks	Energy is registered. The pulse rate is proportional to the consumed power.
	Lit	Voltages applied to the meter, but load current is lower than the meter starting current.
	Not lit	Voltage not applied to the meter.

The emitted pulse rate depends on the meter version and load current.

Meter version	I _{max}	Meter constant
Direct connected (D2)	120 A	500 imp/kWh (500 imp/kVAh 500 imp/kvarh)
Direct connected (D1)	85 A	1.000 imp/kWh (1.000 imp/kVAh 1.000 imp/kvarh)
CT operated (T1)	6 A	10.000 imp/kWh (10.000 imp/kvarh, 10.000 imp/kVAh)

In the meter test mode pulse rate is increased to 40.000 imp/kWh (kVAh/imp and kvarh/imp) in order to shorten time needed for testing the meters at low loads.

On request the imp/kWh - LED can have an additional function. In the RTC test mode operation for testing RTC accuracy it blinks with frequency that is equal to the RTC test frequency i.e. 4.096 Hz (see Item 2.4.2 RTC accuracy testing).

2.7. Push-buttons

Two pushbuttons are built in the meter cover.

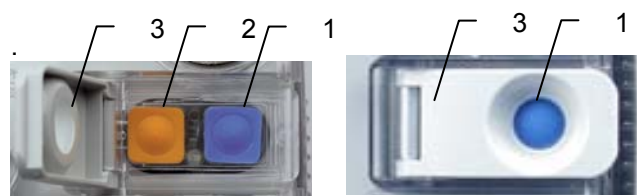

- 1 – Data scroll pushbutton
- 2 – Reset pushbutton
- 3 – Cover of the Reset pushbutton

Fig. 12: Pushbuttons on the meter cover

- **RESET** - an orange pushbutton under the hinged door that is fixed to the meter cover.

Available sealing that does not depend on the meter cover.
Its primary function is to perform manual billing reset of the meter.

- **DATA SCROLL** - a blue pushbutton that is always accessible.
Its primary function is to display data from the Manual sequence on request.

Depending on how long the pushbuttons were pressed and the combination of pressing them, the pushbuttons enable:

- Selection of the meter operation mode,
- Testing of display,
- Listing of metering results
- LCD back-light turn-on (if this function was requested)
- Data display on the LCD in no-power meter state (if this function was requested)
- Manual billing reset of the meter
- Manual setting of the RTC time and date (option),
- Manual setting of data transmission rate (Baud rate) for optical port and serial interface RS485 (if built-in)
- Manual deleting of alarm flags (option),

At the orange pushbutton the time duration of pressing does not influence to its function, while at the blue pushbutton there are three different time durations of pressing - each of them causing different effect:

- a. **Short** - pressing **shorter than 2 sec.** - the next data in the menu is displayed.
- b. **Long** - pressing **longer than 2 sec. and shorter than 5 sec.** - a submenu or a function whose name is displayed on the LCD is selected.
- c. **Prolonged** - pressing **longer than 5 sec.** - the meter is returned up for one level of operation (e.g. on the third level it is necessary to press the blue pushbutton three times and always keep it pressed for more than 5 sec. in order to return to the automatic data display mode).

On request the meters can be without the Reset pushbutton. In such a case the hinged door is ultrasonically welded to the meter cover and it can't be opened. If there is no Reset pushbutton, meter functions that requests pressing it are disabled (e.g. manual meter billing reset, manual setting date and time, etc.).

2.7.1. Display testing

A display is tested to check if all its segments function properly. In the automatic data display the

blue pushbutton should be pressed for a short time ($T_p < 2$ s). The display is tested for 10 seconds and all its segments are displayed. After 10 seconds the meter returns to automatic data display mode automatically (see item 2.5.1).

2.7.2. Manual data display

Data are displayed on request as follows. The meter is set to the display testing mode (see Item 2.7.1). During the LCD test, the blue pushbutton is pressed for a short time ($T_p < 2$ s). The **Std dAtA** title is displayed. In this way a menu for selecting data display on request is entered.



In order to enter into the data display on request menu, the blue pushbutton should be pressed for a long time ($2 \text{ s} < T_p < 5 \text{ s}$). The first data from the Manual scroll list is displayed on the LCD. For displaying the following data from the Manual scroll list, the blue pushbutton should be pressed for a short time again.

If the blue pushbutton has not been pressed for some time, the meter automatically returns back into the Auto scroll mode.

The exit from the Manual data display mode is performed by prolonged pressing the blue pushbutton ($T_p > 5 \text{ s}$).

2.7.3. Manual meter billing reset

For a manual meter billing reset with which the meter is prepared for a new billing period, the seal of the orange pushbutton door should be broken first and the door should be opened. The orange pushbutton should be pressed, when the meter is in the automatic data display mode. When meter billing reset is performed, a message **donE** is displayed on the LCD for a while.



In case of the meter billing reset, the billing data are transferred from the registers for a current month to the registers for a previous month, the registers for demand in a current month are deleted, and the counter of performed billing resets is incremented by one.

In order to prevent misuse of the Reset push-button after the meter billing reset, the orange pushbutton

is disabled for one demand period or longer time (maximum 1.092 minutes) which can be set by MeterView. If the orange pushbutton is pressed in time shorter than the Reset pushbutton disable period, the meter billing reset will not be performed and a message **blockEd** is displayed on the LCD.

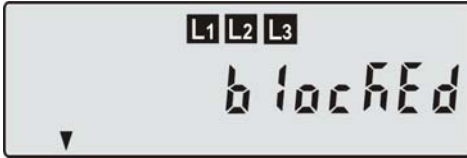

The orange pushbutton cover should be closed and sealed again after the manual meter billing reset was performed.

On request, the function of manual meter billing reset can be disabled.

2.7.4. Meter setting mode

The meter setting mode enables:

- meter parameters setting via the optical port,
- setting date and time of the RTC by means of the pushbuttons separately for communication via the optical port and RS485 (if built-in)
- setting data transmission rates by means of the pushbuttons
- deleting of the alarm flags on the LCD by means of the pushbuttons.

All these functions are optional and can be enabled or disabled. To enter into the meter setting mode the orange pushbutton should be pressed when the meter is in the LCD testing mode. The menu title **SEt** is displayed.



Now the blue pushbutton should be pressed for a long time ($2s < T_p < 5s$) to enter into the **SEt** menu. The first item in the Set menu is displayed. The other items in the Set menu are displayed by short pressing ($T_p < 2s$) the blue pushbutton. There are the following options in the **SEt** menu:

- **0.9.1** register of the RTC current time - the RTC current time can be set by means of the pushbuttons
- **0.9.2** register of the RTC date - the RTC date can be set by means of the pushbuttons
- **C.57.0** register of data transmission rate at the optical port - the data transmission rate at the optical port can be set by means of the pushbuttons

- **C.57.1** register of data transmission rate at the interface (if built-in) - the data transmission rate at the interface can be set by means of the pushbuttons
- **Par SEt** - an option for entering into the meter parameters setting mode which enables setting meter parameters via the optical port
- **Ad rESEt** - an option for manual deleting alarm flags on the LCD

All these functions are optional and can be activated by means of MeterView software. See also a flow chart Pushbutton functions and meter modes in fig. 13 in the item 2.7.6 Driving menus with pushbutton).

2.7.4.1. Setting RTC time by pushbuttons

When 0.9.1 register is displayed on the LCD, the orange pushbutton should be pressed in order to edit current time.



The SET flag is displayed on the LCD indicating that displayed time can be edited and the first digit on the left side starts to blink. It can be incremented by short pressing ($T_p < 2s$) the blue pushbutton.

When its value is suitable, the orange pushbutton should be pressed to confirm it. The next digit starts to blink. In this way all digits are to be edited. When the last digit has been edited, the orange pushbutton should be pressed to set the new time in the RTC (see item 2.7.7 Flowchart of time setting with pushbuttons). At the same time the meter returns back into the **SEt** menu.

2.7.4.2. Setting RTC date by pushbuttons

When 0.9.2 register is displayed on the LCD, the orange pushbutton should be pressed in order to edit current date.



The SET flag is displayed on the LCD indicating that displayed date can be edited and the first digit on the left side starts to blink. It can be incremented by short pressing ($T_p < 2s$) the blue pushbutton.

When its value is suitable, the orange pushbutton should be pressed to confirm it. The next digit starts to blink. In this way all digits are to be edited. When

the last digit has been edited, the orange push-button should be pressed to set the new date in the RTC (see item 2.7.7 Flowchart of time setting with pushbuttons). At the same time the meter returns back into the **SET** menu.

2.7.4.3. Setting Baud rates by pushbuttons

When C.57.0 register is displayed on the LCD, the orange pushbutton should be pressed in order to set Baud rate of data transmission via the optical port.



The SET flag is displayed on the LCD indicating that the displayed Baud rate value can be edited and at the same time the Baud rate value starts to blink. By short pressing ($T_p < 2s$) the blue pushbutton, the possible Baud rate values are scrolled on the LCD (300, 600, 1.200, 2.400, 4.800, 9.600, 19.200 bit/s). When a suitable Baud rate is displayed on the LCD, the orange pushbutton should be pressed to save it. At the same time the meter returns back into the **SET** menu.

In the same manner can be set Baud rate of data transmission via an interface (if it is built-in) in the register C.57.1.

2.7.4.4. Meter parameters setting mode

When a title **PAR SET** is displayed on the LCD, the orange pushbutton should be pressed in order to enter into the meter parameters setting mode.



The SET signal flag is displayed on the LCD and the title **PAR SET** starts to blink indicating that the meter parameters can be programmed via the optical port. To exit from the Meter parameters setting mode the orange pushbutton should be pressed again. At the same time the meter returns back into the **SET** menu.

2.7.4.5. Deleting alarm flags by pushbuttons

When a title **Ad rESEt** is displayed on the LCD, the orange pushbutton should be pressed in order to delete the displayed alarm flags (e.g. meter cover opening, terminal cover opening, reversed energy flow, etc.).

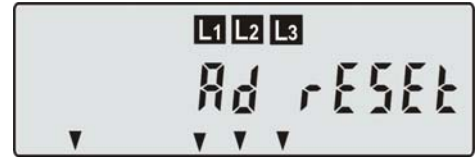

When the orange pushbutton has been pressed, the title **Ad done** and the SET flag are displayed indicating that the alarm flags have been deleted. At the same time the alarm flags displayed on the LCD are turned-off.



The orange pushbutton should be pressed again to return back into the SET menu - **Ad rESEt** title is displayed on the LCD.

By short pressing ($T_p < 2s$) the blue pushbutton a message **End** is displayed on the LCD indicating that there is no more items in the **SET** menu. If the blue pushbutton is pressed again, the first item in **SET** menu is displayed on the LCD.

In order to exit the **SET** menu the blue pushbutton should be prolonged pressed ($T_p > 5s$).

2.7.5. Meter testing mode

The MT174 meters can be set into the testing mode by means of the Reset and Scroll pushbuttons. Data of energy are displayed with increased resolution in the meter testing mode - maximally four decimals can be displayed. A number of decimals that will be displayed in the meter testing mode can be set with the MeterView software.

To enter into the meter test mode the Reset (orange) push-button should be pressed, when the meter is in the LCD testing mode. When title **SEt** is displayed, the blue pushbutton should be pressed short so that title **tESEt** of the submenu meter testing mode is displayed.



The blue pushbutton should be pressed long ($2s < T_p < 5s$) to display energy data with increased resolution.



- with prolonged pressing ($T_p > 5s$) the blue push-button
- to disconnect the meter from voltages.

2.7.6. Driving menus with pushbuttons

There are three different ways to return back into the standard energy data resolution display mode:

- to send an appropriate formatted command to the meter via its optical port

The MT174 meters can be set into different modes (see items 2.7.4, 2.7.4.1, 2.7.4.2, 2.7.4.3, 2.7.4.4 and 2.7.4.5) by means of the pushbuttons. The pushbutton functions and the meter modes are shown in the following flow-chart.

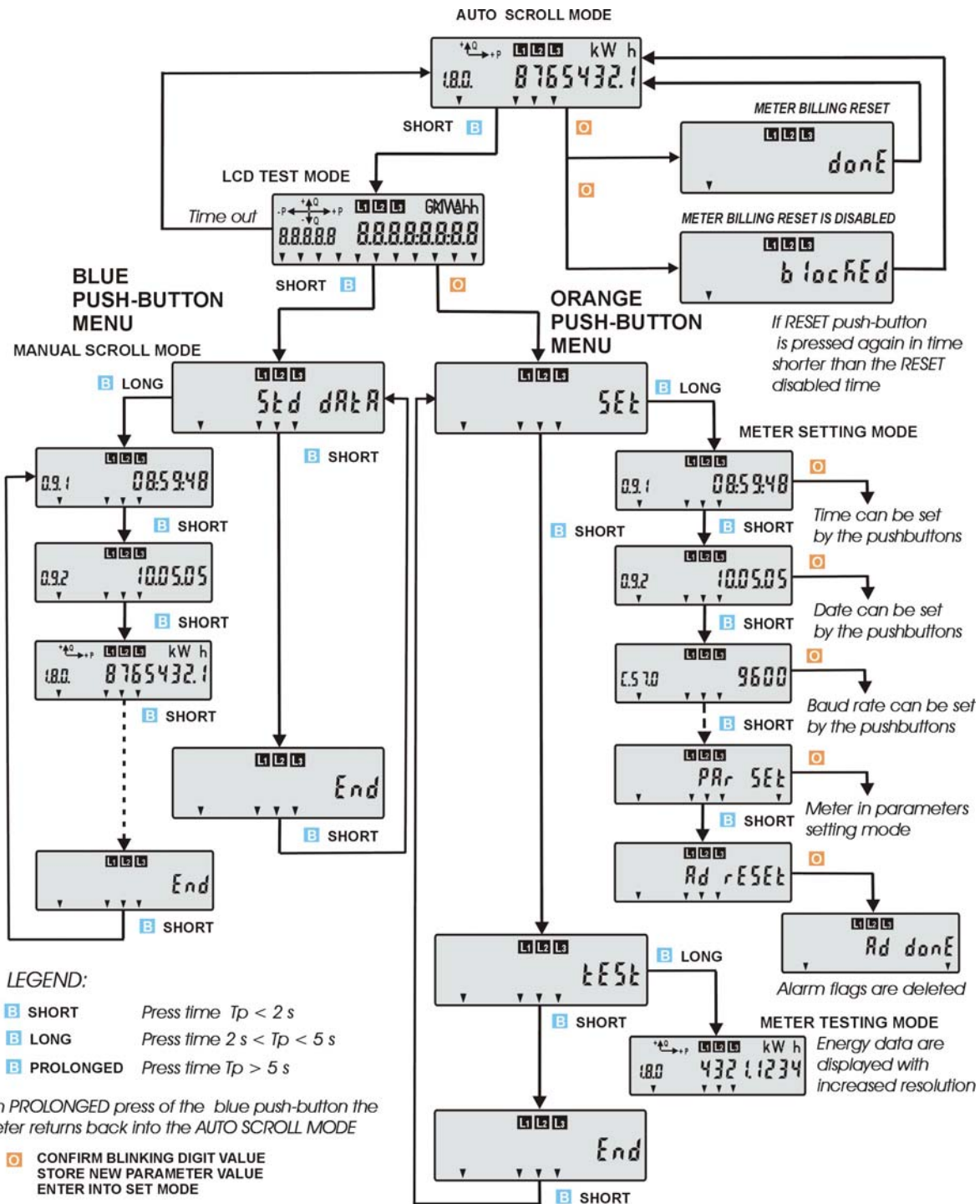

Note: Registers displayed on the LCD in the Manual scroll mode can differ from those shown in the flow-chart as they are optional.

Fig. 13: Pushbutton functions and meter modes

2.7.7. Flowchart of time setting with pushbuttons

Data scroll pushbutton

B SHORT ($T_p < 2s$): Increments digit that blinks

B LONG ($2s < T_p < 5s$): Keeps old parameter value

Reset pushbutton

O: Confirms value of digit that blinks and goes to the next digit

Enters new value of parameter

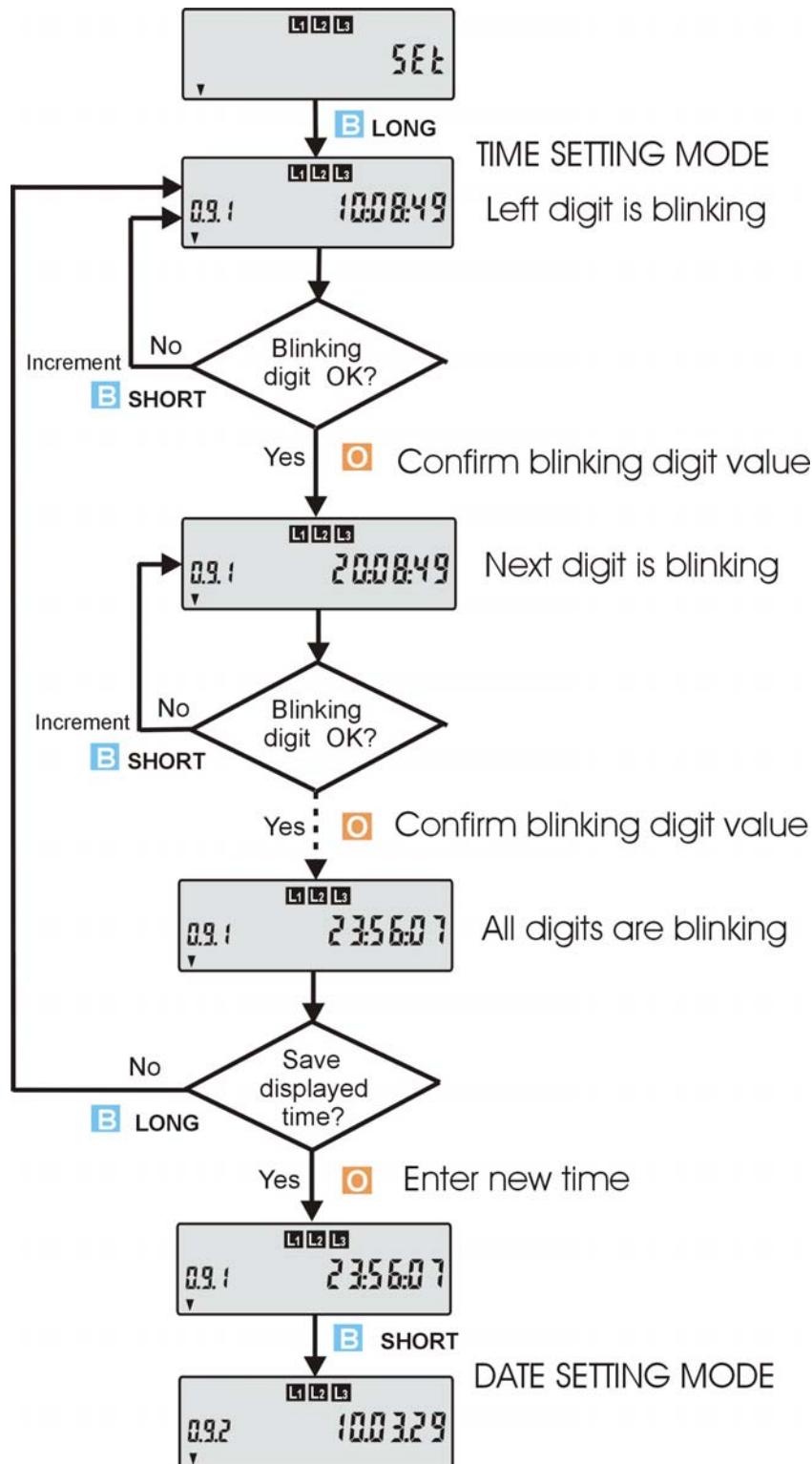

Fig. 14: Flow-chart of time setting with pushbuttons

Date is set with the pushbuttons in the same manner.

2.8. Communication channels

The meters can be equipped with the following communication channels:

- Optical interface (always built-in)
- RS485 interface (on request)

Built-in communication channels enable:

- Billing data readout
- Load-profiles readout
- Log-book registers readout
- Meter parameters readout
- Meter parameters setting

Communication with the meter in progress is indicated on the LCD by the DRO signal flag.

2.8.1. Optical port

In the right top corner of the meter there is an optical port that complies with the IEC 62056-21 standard. It is intended for a local setting of the meter parameters and local data readout.



Fig. 15: Optical port

The communication protocol is IEC 62056-21, mode C. Communication mode is serial asynchronous. All data transmission rates from 300 bit/s to 19.200 bit/s are available. However, the default data transmission rate is 9.600 bit/s. If data transmission rate of the used optical probe is less than 9.600 bit/s, than transmission rate of the optical port should be set to the data transmission rate of the optical probe.

The wave length of the optical port light is 660 nm, luminous intensity in active state is min. 1 mW/sr.

2.8.2. RS485 interface

On request, an RS485 interface can be built into the MT174 meters. It enables remote readout and setting of the meter parameters.

The RS485 interface enables connection of 31 meters to one communicator with a built-in RS485 interface, e.g. Iskraemeco P2CC. Master-slave architecture is used. The communicator is a master device and the MT174 meters are slave devices. Maximum distance between the meters and the

communicator is 1.200 meters. At two-way communication via the RS485 interface the IEC 62056-21, mode C protocol is used. The data transmission rate is fixed and default set to 9.600 bit/s. Anyhow, any other data transmission rate in the range from 300 bit/s to 19.200 bit/s can be set depending on the data transmission rate of the master to which the meter is connected.

The RS485 interface is connected to the auxiliary terminals on the right side of the terminal block.

Terminal	Description
27	RS485 A
29	RS485 B

Note: The meter address could be long up to 20 characters and is stored in the register 0.0.0. It is not allowed that two meters connected to one master device have the same address. If the meter address is not specified by a customer at the meter ordering, the default meter address is the meter serial number.

2.8.3. Data downloaded via optical port

Data downloaded via an interface (optical port or RS485 interface) are identified with OBIS (**OB**ject **I**dentification **S**ystem) codes in compliance with IEC 62056-61 standard. On request the data identification codes can be EDIS (**E**nery **D**ata **I**dentification **S**ystem) in compliance with DIN 43863, Part 3 standard. On request, historical data for previous billing periods, besides data for a current billing period, can be also downloaded via the optical port and an interface (if it is built-in). Historical data can be downloaded for maximum 15 last billing periods.

2.8.4. Fatal error register

The fatal error register F.F.0 is a hexadecimal value and generates the following alarms, when particular bits are set to 1.

Bit	Error Description
0	Firmware check-sum error
1	Parameters check-sum error
2	Energy / maximum demand check-sum error
3	Not implemented
4	Not implemented
5	Not implemented
6	Warning of detected factory access level*
7	Not implemented

* If only a factory access level has been detected, the "Error" message is not displayed

2.8.5. Communication protocol

The communication protocol is IEC 62056-21 mode C. The communication is asynchronous half-duplex.

Data format:

1 start bit, 7 data bits, 1 parity bit, 1 stop bit

The entire data block is protected with a control mark BCC in compliance with the DIN 66219 standard.

After receiving a calling telegram at a 300 baud data transmission rate,

! ? Device address ! CR LF or ! ? ! CR LF

the meter reveals its identification at a 300 baud data transmission rate:

/ I S K 5 M T174 – “Program version”

where “Program version” is a four digit code. The meter address refers to the contents of the 0.0.0 or 0.0.1 registers. Then the meter waits for 2 sec. so that the proposed data transmission rate is confirmed:

ACK 0 5 0 CR LF.

If the proposed baud rate is confirmed, communication at a 9.600 baud rate follows; if it is not confirmed, communication at 300 baud continues. The meter transmits the data telegram:

STX Data ! CR LF ETX BCC

where

- STX: stands for the start of a text;
- Data: refers to codes and data
- ! CR LF: stands for the end of data
- ETX: stands for the end of a text
- BCC: stands for Block Check Character - parity check

2.9. Inputs and outputs

Inputs and outputs are built in the MT174 meters on request. The following inputs and outputs are available:

- Impulse output
- Tariff output
- Tariff input

For possible combinations of inputs and outputs see the item 1.2.3. Auxiliary terminals.

2.9.1. Tariff input

One (two-tariff meters) or two tariff inputs (three or four-tariff meters) for external tariff changeover can be built into the MT174 meters.

Terminal	Designation	Description
13	TE1/2	Tariff input 1
15	GND	Ground
33	TE3/4	Tariff input 2

A tariff input is controlled with AC line-to-neutral voltage U_n . The microcontroller recognize that there is logic 1, if voltage at the input is $U \geq 0.8 U_n$, and logic 0, if voltage at the input is $U \leq 0.2 U_n$.

A customer can specify at which voltage combination applied at the tariff inputs a certain tariff is valid. The customer can also specify whether a tariff input has a ground connected to an auxiliary terminal or it has a common ground with the meter and is therefore connected inside it.

2.9.2. Pulse output

One pulse output (active energy meters for one energy flow direction or absolute meters) or two pulse outputs (active and reactive energy meter for one energy flow direction or active energy meters for two energy flow directions) can be built into the MT174 meters.

Note: Pulse output(s) are not available, if the meter is equipped with tariff output(s).

Terminal	Designation	Description
40	GND	Ground
41	+AA	Pulse output +A
42	-AA	Pulse output -A
43	+RA	Pulse output +R

Note: Besides the 41 terminal either the 42 or the 43 auxiliary terminal can be used.

The pulse output is passive and complies with the IEC 62053-32 standard, class A (S0 in compliance with DIN 43864). The pulse constant is equal to the half value of the meter constant and the standard pulse width is 40 ms. However, a smaller pulse constant or a larger pulse length can be set on request. The class A pulses can be transferred to 0.5 m distance.

The pulse output(s) can be performed as an optomos relay with a make contact that can changeover 25 W (100 mA, 250 V) on request. In this case pulse transmission at a distance of 1 km is made possible. The pulse constant is equal to one tenth of the meter constant and the standard pulse width is 100 ms. However, a smaller pulse constant or other pulse lengths can be set on request.

Optional pulse widths are: 10 ms, 20 ms, 30 ms, 40 ms, 50 ms, 60 ms, 80 ms and 100 ms. The default pulse width is 40 ms at class A pulse output and 100 ms at optomos relay pulse outputs.

Optional pulse constants at direct connected meters are: 1.000 pls/kWh, 500 pls/kWh, 250 pls/kWh, 200 pls/kWh, 100 pls/kWh, 50 pls/kWh, 25 pls/kWh, 20 pls/kWh and 10 pls/kWh.

The default pulse constants depending on the pulse output type and the meter I_{max} current is given in the table below:

Pulse output	Default output pulse constant (pls/kWh)	
	I_{max} up to 85 A	$I_{max} = 100$ A or 120 A
Class A (S0)	500	250
Optomos relay	100	50

Warning: When other than default pulse width and pulse constant are required, attention should be paid that the selected values do not cause overlapping of the pulses at maximum load.

The pulse outputs can be dedicated to any energy which is measured.

2.9.3. Tariff output

One or two tariff outputs can be built into the MT174 meters for controlling an external device by a tariff program that is stored in the meter instead of pulse output(s).

Terminal	Designation	Description
61	TA1/2	Tariff output 1
65	GND	Ground
63	TA3/4	Tariff output 2

A tariff output is performed as an optomos relay with a make contact that can switchover 25 W (100 mA, 250 V).

Note: Tariff output(s) are not available, if the meter is equipped with pulse output(s).

3. Antifraud protection

Special attention has been paid to a system of meter data protection through the MT174 meter design in order to prevent its tampering. Besides, special tamper countermeasures are used hardware and software ones.

3.1. Meter seals

The meter and the terminal block cover are fixed with two screws and are secured with a wire and a lead or a plastic seal. The Reset pushbutton hinged door is sealed separately.

3.2. Always positive registration

The option of always positive energy registration at kWh-meters regardless in which direction energy flows through the metering elements prevents meter misuse by wrong connection of the conductors into the terminal block. In this way registered energy is equal to the one actually consumed regardless of the meter connection.

$$A_{3f} = |±A_{L1}| + |±A_{L2}| + |±A_{L3}|$$

In addition, an alarm flag REV is displayed on the LCD, when energy flows in reversed direction. Besides, a corresponding indicator L1, L2 or L3 is blinking indicating through which of the metering elements energy flows in reversed direction.

Reversed energy can be registered into a separate register on request too.

Besides, the following registers can be implemented into the MT174 meters:

- Elapsed time during which energy flow in reversed direction.
- Events counter of reversed energy flow
- Time-stamps of the last reversed energy events

3.3. Passwords

The MT174 meters are protected with three passwords. They protect the meters against unauthorized:

- reading the meter data
- changing the meter parameters
- setting time and date in the meter RTC.

The passwords can be up to 12 characters long. If wrong password(s) is (are) entered into a meter three times, the communication channel is disabled for a certain time in order to prevent attempts of hacking the meter. Such attempts are also registered into the meter log-book.

Besides, the following registers can be implemented into the MT174 meters:

- Events counter of wrong password entering

- Time-stamps of the last wrong password entering

3.4. Parameters change protected with a sealed pushbutton

Besides protection with a password the meter parameters change can be protected with the Reset pushbutton which is sealed. In such a case the Reset pushbutton seal should be broken and the Reset pushbutton should be pressed before the meter parameters can be changed.

3.5. Detectors of opening meter cover and terminal cover

On request, a detector of the meter and/or the terminal cover opening can be built into the meter. They are two switches with a pushbutton that trigger a signal in case of opening the cover. The event is registered in the log-book together with its time-stamp (date and time) and the corresponding flag is displayed in the LCD.

Besides, the following registers can be implemented into the MT174 meters:

- Fraud energy register (see item 3.10 Registers of fraud energy)
- Events counter of a cover opening
- Time-stamps of the last reversed cover opening events



Fig. 16: A detector of opening the terminal cover

3.6. Detector of external magnetic field

On request, a detector of an external magnetic field can be built into the meter. If an external magnetic field is detected, this event is registered in the log-book together with its time stamp (date and time) and the corresponding flag is displayed in the LCD.

Consumed energy during meter tampering with a permanent magnet can be registered into a separate register on request too.

Besides, the following registers can be implemented into the MT174 meters:

- Fraud energy register (see item 3.10 Registers of fraud energy)
- Elapsed time during which the meter was exposed to an external permanent magnetic field (if a magnetic field detector is built-in).

- Events counter of a meter tampering with a permanent magnet
- Time-stamps of the last meter tampering with a permanent magnet events

3.7. Fraud event counters

On request, the meter is equipped with counters of events that count particular events from 0000 to 9999. They are organized as ring buffers so that after the 9999-th event the new event is registered as 0000. To each event counter is associated a register that registers a time stamp (date and time) of the last event that has occurred. All event counters and registers containing their last time-stamps can be downloaded in the DRO (Data Read Out) sequence via the optical port and via a serial interface (RS485), if it is built-in. The events and their time-stamps are registered in the following registers.

REGISTER	DATA CONTAINED
C.51.1	Terminal cover opening counter
C.51.2	Timestamp of the last terminal cover opening event
C.51.3	Meter cover opening counter
C.51.4	Timestamp of the last meter cover opening event
C.51.5	External magnetic field influence event counter
C.51.6	Timestamp of the last external magnetic field influence
C.51.7	Reversed energy flow event* counter
C.51.8	Timestamp of the last reversed energy flow event*

* Available only at the meters for measurement energy in one energy flow direction or absolute energy.

Events of meter and terminal cover opening are registered even if they are opened when there is no voltage applied to the meter.

3.8. Registers of elapsed time

The MT174 meters enable registration of elapsed time:

- since the start of energy measurement
- how much time was energy measured in a particular tariff
- how much time energy has flown in reversed direction (only at one energy flow direction meters and at absolute ones)
- how much time the meter was exposed to a permanent magnetic field (if a magnetic field detector is built-in)

Besides, the meters have a counter which registers elapsed time during which no voltage has been applied to the meter.

Elapsed times can be expressed either in hours - in such a case five digits are available or expressed in a form of YYMMDDhhmmss

where:

YY - years, MM - months, DD - days, hh - hours

mm - minutes, ss - seconds

3.9. Registers of fraud energy

The MT174 meters have four registers in which energy is separately registered during the meter tampering besides energy registered in the corresponding registers. The fraud energy registers are available for the following tamper attempts:

- reversed energy flow direction (only at one energy flow direction meters and at absolute ones)
- permanent magnetic field exposure (if a magnetic field detector is built-in)
- energy registered since the meter and/or terminal cover has been opened

Besides, time how long a particular fraud has lasted is registered in the corresponding register of elapsed time (see item 11. Tamper registers (energy registers and registers of elapsed time) in the 11. Appendix II: EDIS codes, data stored in registers, sequences, historical values).

3.10. Log-books

All events are registered also in the log-books (see item 2.3.2) together with their time stamps (date and time of the event occurrence).

3.11. SEP2 MeterView software

SEP2 MeterView software for meter managing is available on request instead of the standard MeterView software. The SEP2 MeterView enables:

- Logging of a user to the SEP2 MeterView software by entering its user name and its password
- Multi level authorisation (meter reading, time and date setting, changing meter parameters, deleting energy registers)
- Data base keeping data who, when and what has done with a particular meter.

4. Meter installation

1. Check if voltage and maximum current printed on the meter name plate correspond to the voltage in the network and to the current which will flow through the meter.
2. Fix the meter with three screws to the measuring place.
3. Connect the meter in compliance with the connection diagram which is stuck in the inner side of the terminal cover (or printed on the meter name plate).
4. Tighten the terminal screws with appropriate torque. The recommended torque for tightening current terminal screws is 2.5 Nm.
5. Check the meter operation indicators:
 - kWh/imp (kvarh/imp) LED is lit (load current is smaller than the meter starting current)
 - kWh/imp (kvarh/imp) LED is blinking with frequency that is proportional to the measured demand (the meter measures and registers energy)
 - kWh/imp (kvarh/imp) LED is not lit (the meter is in no-power state). In this case the following should be checked:
 - a) At directly connected meters: voltage links in lower position (if not, the voltage links slides should be moved to their lower position)
 - b) Connected current conductors to the meter (if not, they should be connected)
 - c) If both above conditions are fulfilled, it means that there is no voltage in the network. If there is a voltage in the network, something is wrong with the meter. In such a case the meter should be replaced.
6. Check the **L1**, **L2** and **L3** indicators on the LCD if current conductors are connected correctly:
 - **L1 L2 L3** indicators are displayed - all three phase voltages are present
 - Some of the **L1 L2 L3** indicators are not displayed (voltage in these phases is not present). Check if current conductors of these phases are connected and/or their voltage links are in the bottom position (at direct connected meters) or find the reason for the phase voltage absence and eliminate it.
 - Some of the **L1 L2 L3** indicators are blinking and at the same time import energy indicator is displayed indicating that current through that metering element is reversed. In such a case change the input and the output of the corresponding current terminals.
 - **L1 L2 L3** indicators are blinking - reversed phase sequence that causes rotation of

magnetic field in reversed direction. In this case check current conductors sequence in the meter or find the place of reversed voltage phase sequence and connect them correctly.

Note: Reversed phase sequence does not influence in energy measurement accuracy

7. Check if alarm flags are displayed on the LCD and delete them. If necessary, remove a cause that they are displayed.
8. Check RTC date and time and correct them, if necessary.
9. Perform a meter billing reset (press the orange pushbutton)
10. Seal the meter (the terminal cover and the orange pushbutton cover).

5. Tools for meter managing

The following tools are used for managing the MT174 meters:

- **For service meter programming and local data downloading:**
 1. MeterView or alternatively SEP2 MeterView (Iskraemeco software)
 2. Optical probe
 3. PC: a desk-top or a lap-top with operating system Windows XP or later Windows version

The tool is intended for the operators who service or reprogram the meters in the laboratory or in the field.

- **For local data downloading and meters programming in the field**
 4. MeterRead (Iskraemeco software) for all type of palm-top PCs operating in the Windows Mobile operating system
 5. Optical probe
 6. Palm-top PC with Windows Mobile

The tool is intended for a personal who read-out the meters in the field.

6. Meter maintenance

The meter is designed and manufactured in such a way that no maintenance is required in the entire meter lifetime. Measuring stability assures that no recalibration is required. If a battery is built into the meter, its capacity is sufficient to backup all meter functions for its entire lifetime.

7. Meter connection diagram

The meter connection diagram is stuck on the inner side of the terminal block cover or is printed on the meter nameplate. The meters can be connected in three-phase four- or three-wire networks, as well as in a single-phase two-wire network.

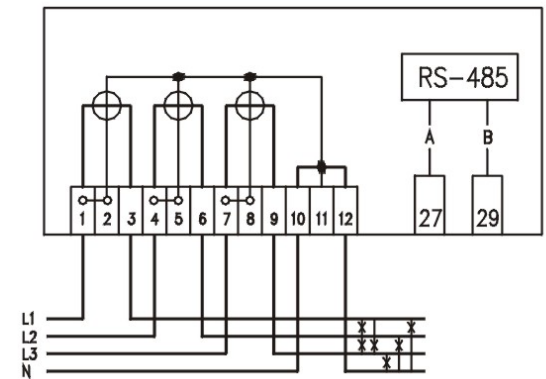
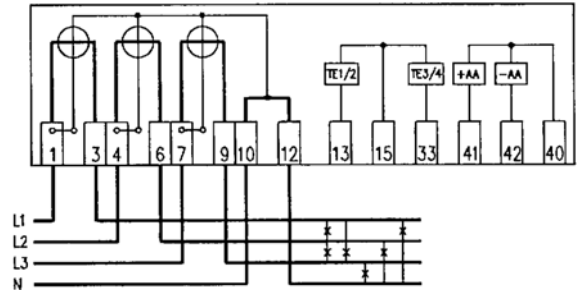

a. Connection diagrams of direct connected meters MT174

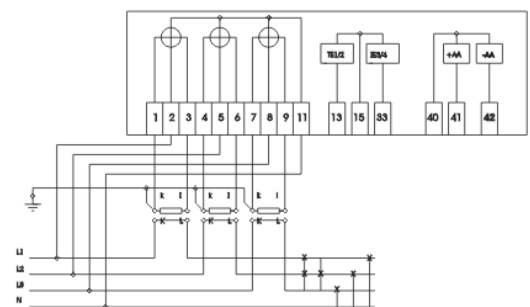

b. Connection diagram of CT operated meter MT174

Fig. 17: Connection diagrams of MT174

(150 kHz...80 MHz)	
Impulse voltage	12 kV, 1,2/50 μ s - to main circuits 6 kV, 1,2/50 μ s - to auxiliary circuits
Radio interf. supr.	(EN 55022) class B equipment
DIMENSIONS AND MASS	
Meters with long terminal cover:	
Dimensions (w x h x d)	178 x 250 x 55 mm
Meters with short terminal cover:	

Dimensions (w x h x d)	177x 216 x 55 mm
Mass	approx. 1,0 kg
COMBUSTIBILITY OF METER CASE	
Class	V0 (Standard UL 94)
TORQUE FOR TERMINAL SCREWS	
Direct connected meters	2.5 Nm
CT operated meters	1.0 Nm