

OB4374

Three phase Multi-circuit meter

Compatible with 0.33V CT and Rogowski coils



Owen Brothers Metering UK Ltd.

Glen Trading Estate, Oldham OL4 3BF-ENGLAND

Tel : 0044-161-6246211

Email : sales@owen-brothers.com

Website : www.owen-brothers.com

Contents

| | |
|--|----|
| BENEFITS AND MAIN FEATURES | 1 |
| 1. TECHNICAL DESCRIPTION | 2 |
| 1.1 METER SPECIFICATION | 2 |
| 1.2 MOUNTING | 2 |
| 1.3 ACCURACY | 3 |
| 2. OPERATION | 3 |
| 2.1 INITIALIZATION DISPLAY | 3 |
| 2.2 SCROLL DISPLAY | 3 |
| 2.3 CHANGE DEFAULT SETTINGS VIA BUTTONS | 6 |
| 3. WIRING DIAGRAMS | 7 |
| 3.1 VOLTAGE/CURRENT TERMINALS | 7 |
| 3.2 OTHER TERMINALS | 7 |
| 3.3 RS485 WIRING | 8 |
| 4. DIMENSIONS | 8 |
| 5. AVAILABLE MEASUREMENTS | 9 |
| 6. COMPATIBLE WITH ROGOWSKI COILS | 10 |
| 7. PULSE OUTPUTS | 11 |
| 8. DC 5V OUTPUT | 11 |
| 9. USED FOR PHOTOVOLTAIC SYSTEMS | 11 |
| 10. IN EV CHARGING SYSTEM | 12 |
| 11. TECHNICAL SUPPORT | 12 |

OB4374

Multi-circuit, Multi-function, DC 5V, S0,RS485 output

- Modular DIN-rail housing,4U (72mm Wide)
- Three phase CT with RJ12 terminal , easy click technology into plug in solution
- Dual load option 2 × 3 phase , 6×1 phase or 1×3 phase plus 3×1 phase circuits
- System wiring method Y/ Δ , Voltage L-L from 208V up to 415V
- Main electrical parameters measured and displayed
- Phase sequence indication
- Voltage Asymmetry (Phase-Phase, Phase-Neural) ,Current Asymmetry
- L1,L2,L3 Voltage THD, L1,L2,L3,N current THD
- Max & Min & Average & demand measure
- System and phase bidirectional energy
- 5V DC output for communication equipment
- LCD display, large clear backlight display for perfect reading
- Monitoring of the energy-consumption goes via a S0 pulse output
- Built-in RS485 communication port, modbus protocol
- The programming switch is protected by lead seal on the upper cover
- Available the remote firmware upgrade of the instrument



Voltage, Current
THD

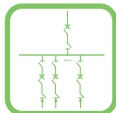

Multi-Circuit



5V DC Output

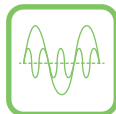

Power Quality



Easy click technology

» 1. Technical description

• 1.1 Meter specification

| | | |
|--|--|--------------------------|
| Nominal voltage(Un) | 3P4W: 3×120/208V , 3×220/380V , 3×230/400V , 3×240/415V 3P3W: 3×100V , 3×208V , 3×220V , 3×230V , 3×415V | |
| Voltage range(v) | (0.8~1.3)Un | |
| Nominal Input | 0.33V CT | 80A, 100A |
| | Rogowski coil | 400A, 600A, 1000A, 3000A |
| Power consumption of voltage circuits(W) | < 1.3 | |
| Frequency (Hz) | 50/60 | |
| Pulse constant(imp/kWh) | See nameplate for details | |

• 1.2 Mounting

| | |
|--|--|
| Mounting | On 35mm rail, according to EN60715TH35 |
| Voltage/Current terminals | 0~2.5mm ² /2Nm |
| Another terminals | 0.5~1mm ² /0.2Nm |
| RS485 cable | AWG18 |
| Ambient temperature | -25°C ~ +55°C |
| Storage temperature | -40°C ~ +70°C |
| Mechanical environment | M1 |
| Electromagnetic environment | E2 |
| Protection against penetration of dust and water | IP51 |
| Relative humidity | 75% without condensation |
| Protect class | II |
| Pollution degree | 2 |

• 1.3 Accuracy

| | |
|-------------------------|-----------------------|
| Voltage | 0.5% of range maximum |
| Current | 0.5% of range maximum |
| Frequency | 0.2% of mid-frequency |
| Power factor | 1% of unity (0.01) |
| Active power (kW) | ± 1% of range maximum |
| Reactive power (kvar) | ± 1% of range maximum |
| Active energy (kWh) | Class 1 IEC 62053-21 |
| Reactive energy (kvarh) | Class 2 IEC 62053-23 |

» 2.Operation

• 2.1 Initialization Display

| | |
|--|---|
| | Full screen, display test It will last for 2 seconds |
| | Software & Hardware version, CRC verify It will last for 2 seconds |

• 2.2 Scroll display

















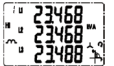



The buttons operate as follow

| | |
|--|---|
| | Scroll up the display screen And change the parameter (decrease 1) |
| | Scroll down the display screen And change the parameter (increase 1) |
| | Confirm when a parameter has been changed |

The meter can setup the display items by RS485. The meter can display max 20 screens in scroll display and 40 screens by button pressing.

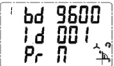
Programmable display content as following CH2 display code = CH1 display code + 100

| | | | | | | | |
|-----|--|-----|--|-----|--|-----|--|
| 101 | | 102 | | 103 | | 104 | |
| | Total active energy serial number | | CH1 Import active energy S02 output impulse/kWh | | CH1 L1-L3 import active energy | | CH1 Export active energy |
| 105 | | 106 | | 107 | | 108 | |
| | CH1 L1-L3 export active energy | | CH1 Total active power Total reactive power Total power factor | | CH1 Total apparent power MD Total active power MD | | CH1 Instant Phase to neutral voltage |
| 109 | | 110 | | 111 | | 112 | |
| | CH1 Maximum Phase to neutral voltage | | CH1 Minimum Phase to neutral voltage | | CH1 Average Phase to neutral voltage | | CH1 Instant Phase to phase voltage |
| 113 | | 114 | | 115 | | 116 | |
| | CH1 Maximum Phase to phase voltage | | CH1 Minimum Phase to phase voltage | | CH1 Average Phase to phase voltage | | CH1 Instant current of each phase |
| 117 | | 118 | | 119 | | 120 | |
| | CH1 Maximum current of each phase | | CH1 Minimum current of each phase | | CH1 Average current of each phase | | CH1 Max current demand of each phase |
| 121 | | 122 | | 123 | | 124 | |
| | CH1 Instant active power of each phase | | CH1 Maximum active power of each phase | | CH1 Minimum active power of each phase | | CH1 Average active power of each phase |

| | | | | | | | |
|-----|--|-----|---|-----|---|-----|---|
| 125 |  | 126 |  | 127 |  | 128 |  |
| | CH1 Maximum active power demand of each phase | | CH1 Instant reactive power of each phase | | CH1 Maximum reactive power of each phase | | CH1 Minimum reactive power of each phase |
| 129 |  | 130 |  | 131 |  | 132 |  |
| | CH1 Average reactive power of each phase | | CH1 Instant Apparent power of each phase | | CH1 Maximum Apparent power of each phase | | CH1 Minimum Apparent power of each phase |
| 133 |  | 134 |  | 135 |  | 136 |  |
| | CH1 Average Apparent power of each phase | | CH1 Maximum Apparent power demand of each phase | | CH1 Instant power factor of each phase | | CH1 Maximum power factor of each phase |
| 137 |  | 138 |  | 139 |  | 140 |  |
| | CH1 Minimum power factor of each phase | | CH1 Average power factor of each phase | | CH1 Voltage THD | | CH1 Current THD |
| 141 |  | 142 |  | 143 |  | 144 |  |
| | CH1 Baud rate Modbus id Parity | | CH1 CT primary | | CH2 CT primary | | CRC Software version Hardware version |

2.3 Change Default settings via buttons

After a long pressure (3 seconds) on SET button in the scroll display, the Set-up screen will appear. Steps :

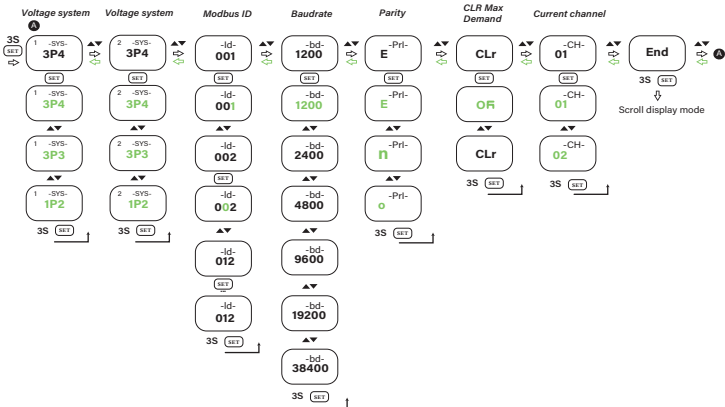

| >> General | >> Unit | >> Default | >> Range |
|--------------------|---------|------------|---------------------|
| Modbus ID | / | 001 | 001---255 |
| Baud rate | bps | 9600 | 1200---38400 |
| Prity | / | None | None,Even,ODD |
| Type of wiring | / | 3P4W | 3P4W(Y) 3P3W(Δ) |
| Current channel ID | / | 01 | 01.02 |

» 3.Wiring diagrams

• 3.1 Voltage/Current terminals

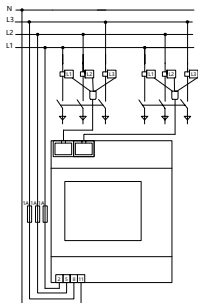

3P4W

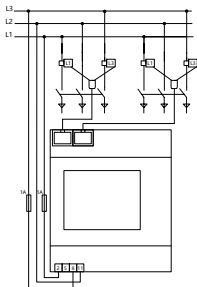

3P3W

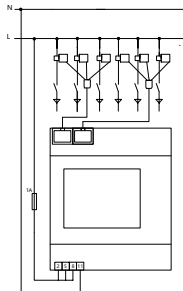

1P2W

• 3.2 Definitions of other terminals

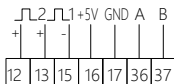

12&15

Programmable S02 pulse output (12+, 15—)

13&15

Active test pulse output S01 contact (13+, 15—)

16&17

5V DC output (16 +5V, 17 GND)

36

RS485 communication contact RS485A

37

RS485 communication contact RS485B

• 3.3 RS485 Wiring

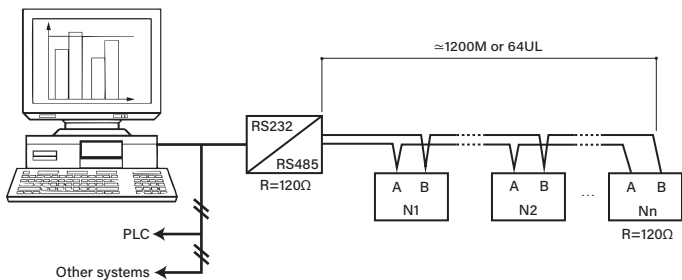

>> 4.Dimensions (mm)

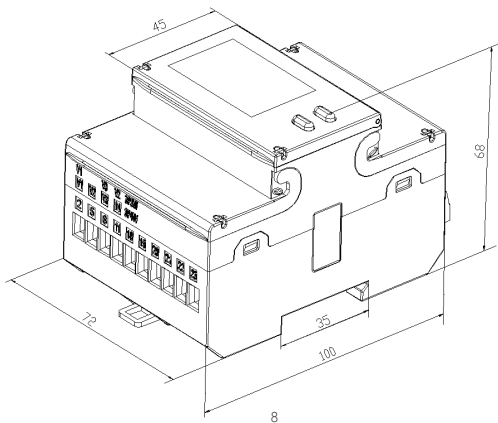

» 5. Available measurements

The following table shows the complete instrumentation functions of all OB4374 meters. Depending on the meter's setting all or a subset of the following functions are available.

| » Active energy | » Unit | » System | » Phase | » Electrical variable | » Unit | » 3P4W | » 3P3W | » 1P2W |
|-------------------|--------|----------|---------|-----------------------|--------|--------|--------|--------|
| L1 import (+) | kWh+ | | ● | Voltage L-N | V | ● | | ● |
| L1 export (-) | kWh- | | ● | Voltage L-L | V | ● | ● | |
| L2 import (+) | kWh+ | | ● | Current L1 | A | ● | ● | ● |
| L2 export (-) | kWh- | | ● | Current L2 | A | ● | | |
| L3 import (+) | kWh+ | | ● | Current L3 | A | ● | ● | |
| L3 export (-) | kWh- | | ● | Current N | A | ● | | ● |
| Import (+) total | kWh+ | ● | | Current, total | A | ● | ● | ● |
| Export (-) total | kWh- | ● | | Active power, total | kW | ● | ● | ● |
| Total | kWh | ● | | Active power, L1 | kW | ● | ● | ● |
| » Reactive energy | » Unit | » System | » Phase | Active power, L2 | kW | ● | | |
| L1 import (+) | kvarh+ | | ● | Active power, L3 | kW | ● | ● | |
| L1 export (-) | kvarh- | | ● | Reactive power, total | kvar | ● | ● | ● |
| L2 import (+) | kvarh+ | | ● | Reactive power, L1 | kvar | ● | ● | ● |
| L2 export (-) | kvarh- | | ● | Reactive power, L2 | kvar | ● | | |
| L3 import (+) | kvarh+ | | ● | Reactive power, L3 | kvar | ● | ● | |
| L3 export (-) | kvarh- | | ● | Apparent power, total | kVA | ● | ● | ● |
| Import (+) total | kvarh+ | ● | | Apparent power, L1 | kVA | ● | ● | ● |
| Export (-) total | kvarh- | ● | | Apparent power, L2 | kVA | ● | | |
| Total | kvarh | ● | | Apparent power, L3 | kVA | ● | ● | |
| » Apparent energy | » Unit | » System | » Phase | Power factor, total | PF | ● | ● | ● |
| Import (+) | kVAh+ | ● | | Power factor, L1 | PF | ● | ● | ● |
| Export (-) | kVAh- | ● | | Power factor, L2 | PF | ● | | |
| Total | kVAh | ● | | Power factor, L3 | PF | ● | ● | |
| | | | | Frequency | Hz | ● | ● | ● |

» 6. Compatible with Rogowski coils

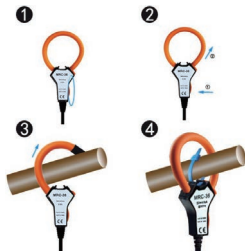
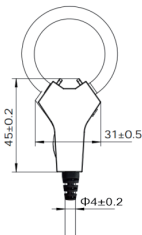

| » Window size | » Ratio | » Lead length |
|---------------|-----------|---------------|
| Φ 16 | 22.5mV/kA | 0.5m |
| Φ 24 | 50mV/kA | 1m |
| Φ 36 | 56mV/kA | 1.5m |
| Φ 50 | ... | 5m |

Note: In order to achieve higher measurement accuracy, Please make sure the CT and Coils are clamped well.

If you inform Owen brothers in advance about the current range you require, it will help to improve measurement accuracy. Owen brothers will calibrate the device according to the specific current range. In case of any queries or issues, please feel free to contact our technical support team through: sales@owen-brothers.com.

» 7.Pulse outputs

Meters equipped with pulse outputs up to 2 outputs. On the terminal 13 and 15, the meter sends out a specified number of pulses per kilowatt. Terminal 12 and 15, S02 output generating pulses for remote processing of the instantaneous active energy . You should set a proper value of pulse frequency and pulse width to avoid pulse missing due to over-counting.

Users can switch the current metering channel (default CH1) to output power pulse indications for different distribution circuits through buttons or RS485 programming. When the current operating channel is 1, S01 and the LED light indicate the power consumption of channel 1. If the current operating channel is 2, S01 and the LED light represent the power consumption of channel 2.

» 8.DC 5V output

Terminal 16 & 17 supply 5V DC Power output, 2 watts as appropriate for powering external communication devices.

» 9.Used for photovoltaic systems

CH1 is connected between the inverter and the household load, which is mainly used for measuring the total power generation of the photovoltaic system. CH2 is connected between the household load and the power grid, which is mainly used for measuring and generating electricity. When the user cannot consume all the electricity produced by PV, the remaining power will export to the grid. Then it is recorded as negative power or negative electric energy; When the PV power generation cannot meet the needs of users to purchase electricity from the grid, it is recorded as positive power or positive electric energy.

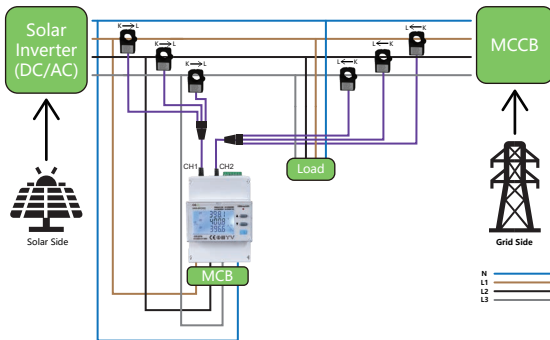

» 10. In EV charging System

The OB4374 dual-circuit meter is particularly suitable for 380V AC dual-gun charging stations, compatible with various output power levels such as 21/16/11/7/3.5kW.

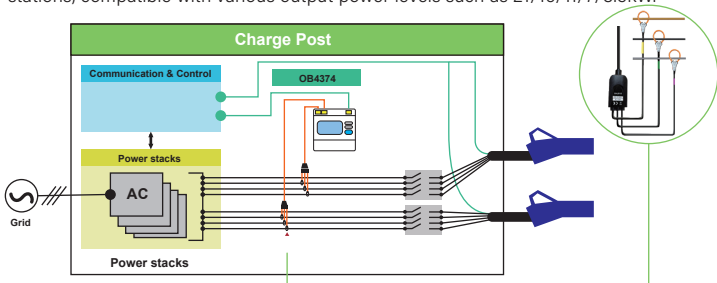

» 11. Technical support

Any questions, please contact:

TEL : 0044-161-6246211

Email : sales@owen-brothers.com